



NV14 Energy Storage System

Installation Manual

(With optional NV24 additional battery capability)

**Installation shall comply with the current version of the IFC, IRC, IBC
or your state's equivalent applicable codes**

Table of Contents

Safety Information	1
1.1 Symbols Used in Manual.....	1
1.2 General Safety Warnings	1
1.3 Safety Instructions.....	2
2 Product Description.....	3
2.1 Product Overview	3
2.2 System Architecture	5
3 Tools and Materials.....	5
4 Unpacking.....	6
4.1 Parts List.....	6
4.2 Preparing Cabinet for Installation.....	6
4.3 Preparing Batteries for Installation.....	7
4.3.1 Battery Unique ID Setting.....	7
4.3.2 Battery Sleep Mode	8
5 Installation Requirements	9
5.1 Site Location and Prep	9
5.1.1 Cabinet Dimensions	9
5.1.2 Clearance Requirements	10
5.1.3 Critical Load Box	11
5.1.3.1 Critical Load Box Circuits	11
5.1.4 Indoor Location Preparation.....	12
5.1.5 Outdoor Location Preparation.....	12
5.1.6 Securing the NV14	13
5.2 Optional Battery Cabinet Installation	14
5.3 Site Location and Prep	14
5.3.1 Battery Cabinet Dimensions.....	14
5.3.2 Location Preparation and Securing the Optional Battery Cabinet.....	14
5.3.3 Clearance Requirements	15
6 Electrical Connections	16
6.1 Wiring	16
6.1.1 Utility Grid Connection.....	16
6.1.2 PV1, VDC Connection (PV2, VDC Connection, if present)	17

6.1.3	PV, VAC Connection or Generator Connection.....	17
6.1.4	Output Connection	18
6.1.5	Optional Battery Connection.....	18
6.2	Battery Installation	20
6.2.1	Battery 1 Installation Instructions.....	21
6.2.2	Battery 2 and 3 Installation	21
6.2.3	Battery 4 and 5 Installation (Optional Battery Cabinet).....	22
6.3	Battery Wiring Connections	22
7	Operation	23
7.1	Applying Power	24
8	System Settings.....	24
8.1	Operation and Display Panel	25
8.2	LCD Display Icons.....	26
8.2.1	Main Screen.....	25
8.2.1.1	Features of the Main Screen	26
8.2.2	System Setup Menu	27
8.2.2.1	Basic Setting	27
8.2.2.2	Battery Setting.....	28
8.2.2.3	System Work Mode.....	28
8.2.2.4	Grid Setting.....	29
8.2.2.5	Gen Port Use.....	30
8.2.2.6	Advanced Functions	30
8.2.2.7	Device Info.....	30
9	Setup WiFi Data Logger	30
10	Installing Front Covers.....	31
11	Specifications	32
12	Technical Reference	33
13	Contact Information	33
14	Appendix.....	34
14.1	Schematic.....	34
14.2	Fault Messages.....	35

Safety Information

1.1 Symbols Used in Manual



WARNING: This indicates a fact or feature very important for the safety of the user to prevent injury or death and/or which can cause serious hardware damage if not applied appropriately.



CAUTION: Presents information to prevent damage to this product

1.2 General Safety Warnings



WARNING: Do not attempt to self-install the NV14 Energy Storage System. A qualified solar installation professional or electrician must install and commission NeoVolta energy equipment. Contact NeoVolta for a list of Authorized installers in your region.



SHOCK RISK: HIGH VOLTAGE ELECTRICITY



WARNING: Before installing the NV14 Energy Storage System, read all instructions and caution markings in this guide and installation manual.



WARNING: Electrical installation in the United States shall be done in accordance with all local electrical codes and/or the National Electrical Code (NEC), ANSI/NFPA 70.



WARNING: Connecting the NV14 Energy Storage System to the electric utility grid must only be done after receiving prior approval from the utility company and installation completed only by qualified personnel/licensed electrician(s).



WARNING: This equipment is NOT intended for use with life support equipment or other medical equipment or devices.



WARNING: For continued protection against risk of fire, replace any fuses only with same type and rating.

1.3 Safety Instructions

This chapter contains important safety and operating instructions. Read and keep this manual for future reference.



CAUTION: Before using the NV14 Energy Storage System, please read the instructions and warning signs of the battery and corresponding sections in the instruction manual.



WARNING: Do not disassemble the NV14 Energy Storage System. If you need maintenance or repair, contact an authorized NeoVolta service dealer. Improper reassembly may result in electric shock or fire.



WARNING: To reduce risk of electric shock, disconnect all wires before attempting any maintenance or cleaning.



CAUTION: Strictly follow installation procedure when you want to disconnect AC or DC terminals. Refer to Installation section of this manual for the details



WARNING: The NV14 Energy Storage System must be connected to a permanent grounded wiring system.



CAUTION: Disconnect all smart batteries and set them to 'sleep mode' before servicing the inverter or touching electrical terminals. Refer to smart battery documentation for complete safety instructions.



CAUTION: Be very careful when working with metal tools on or around batteries. Dropping a tool may cause a spark or short circuit in batteries or other electrical parts. Additionally, risk of battery explosion is possible.



WARNING: PV modules pass direct current (DC) when the module is under load. Direct current will arc across gaps and may cause injury or death if improper connection or disconnection is made. Do not connect or disconnect wires to the NV14 Energy Storage System when current from the modules or an external source is present.

2 Product Description

2.1 Product Overview

This is a multifunctional inverter, combining functions of inverter, solar charger, and battery charger to offer uninterruptible power support with portable size. This is a multifunctional inverter, combining functions of inverter, solar charger, and battery charger to offer uninterruptible power support with portable size. Its comprehensive LCD display offers user configurable and easily accessible button operation such as battery charging current, AC/solar charger priority, and acceptable input voltage based on different applications.

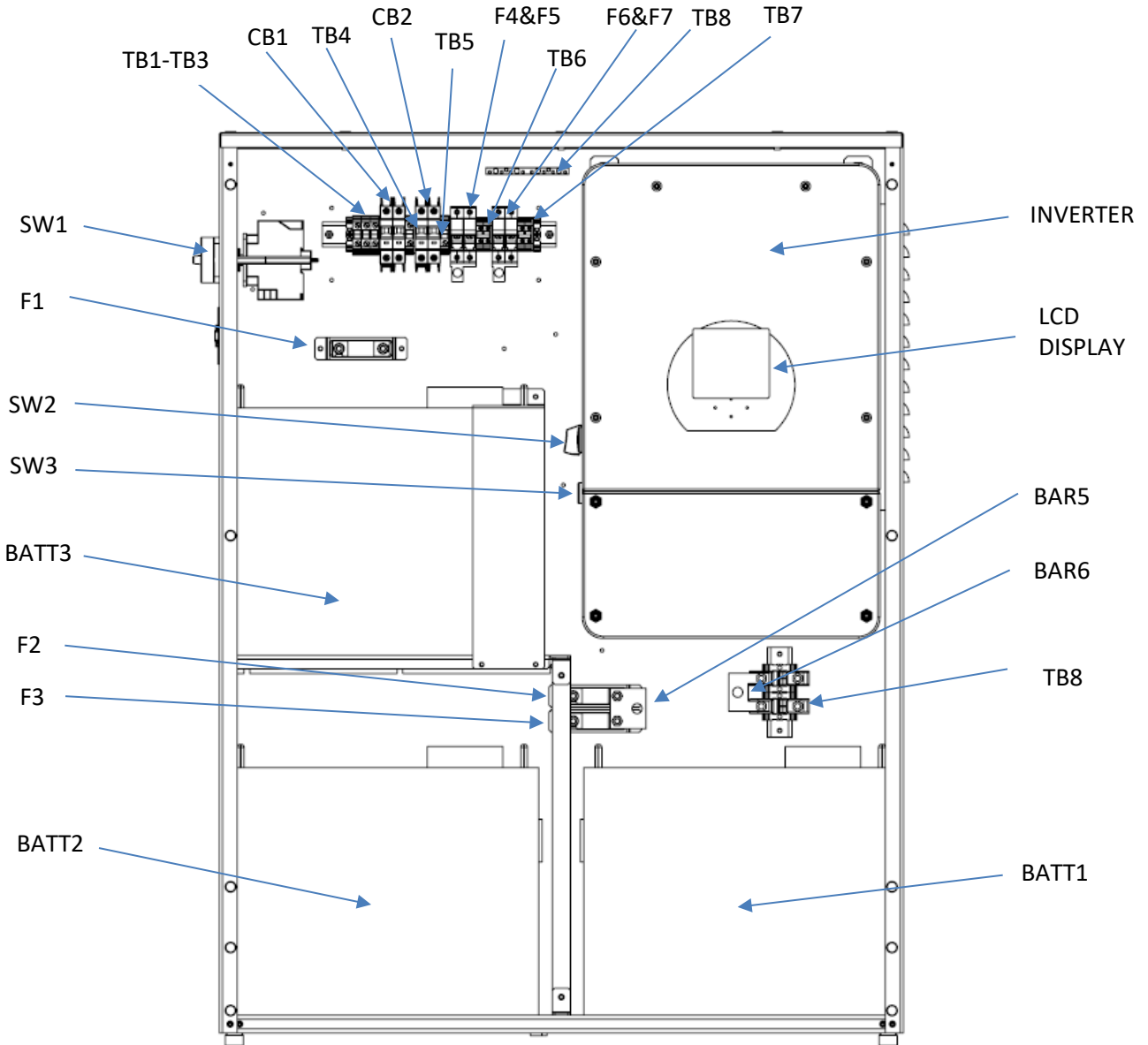

Figure 1

Component Locations (Figure 1)

SW1	System Disconnect Switch
CB1	Grid Input Circuit Breaker
TB1	Grid Input Neutral Terminal
CB2	PV AC, or Generator Input Circuit Breaker
TB2	PV AC, or Generator Input Circuit Breaker Neutral Terminal
CB3	Output Circuit Breaker
TB3	Output Neutral Terminal
F4-F5	PV1 '+' Input Fuses
TB4	PV1 '-' Input Terminal
F6-F7	PV2 '+' Input Fuses
TB5	PV2 '-' Input Terminal
BATT1	Battery
BATT2	Battery
BATT3	Battery
F1	BATT1 Fuse '+'
F2	BATT2 Fuse '+'
F3	BATT3 Fuse '+'
TB6	Ground Bar
SW2	Inverter ON/OFF Switch
SW3	Inverter DC Bus ON/OFF Switch
BAR5	Battery '+' Junction
BAR6	Battery '-' Junction
TB8	Battery '-' Junction Terminals

2.2 System Architecture

The following shows the basic architecture of the NV14 Energy Storage System with the various devices that are acceptable interfaces to the system (Figure 2). It is the responsibility of the authorized installer to determine the specific devices and interface requirements at each location.

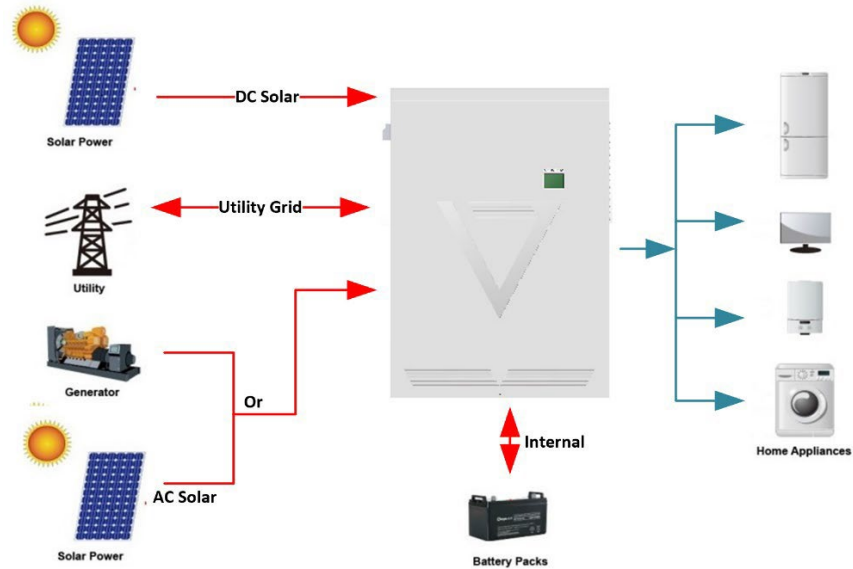

Figure 2

3 Tools and Materials

- Digital Voltmeter
- AC/DC Clamp-on Current Meter
- Drill + 3/8" Drill
- Tape Measure
- Stud Finder
- Hand Cart
- Screw Drivers (Philips and small blade)
- Socket wrench with 9/16" socket
- Code-compliant conduit and wire
- 5/32" (or 4mm) Hex key tool

4 Unpacking

4.1 Parts List

The NV14 Energy Storage System is delivered in 2 separate packages:

- Cabinet
- Three (3) individual batteries
- Installation Kit
 - Wall Mounting Bracket (2)
 - 3/8 x 2" Lag Bolt (4)
 - 3/8 Flat Washer (4)
 - 2.4 and 5.0 GHz Wifi Data Logger
 - 10 ft Wifi Extender Cable
 - White Screw Caps (10)
 - Bag of cable clips and Wi-Fi mounting screws
 - Abbreviated Installation Manual
 - Solarman Wifi Installation Manual
- Critical load panel with 40A back feed breaker

4.2 Preparing Cabinet for Installation



WARNING: The NV14 Energy Storage System cabinet, without batteries, weighs 265 lbs. (114kg).

Move the cabinet, as shipped, as close to the installation site as possible

- Remove the front cover. Set aside for future use.
- Remove the lower front cover. Set aside for future use.
- Stand the cabinet upright. Remove the Accessory Box and Sub-Panel and set aside.



WARNING: The cabinet, without batteries, is top heavy. Take care not to tip over cabinet prior to securing it to its permanent location.

The NV14 Energy Storage System cabinet has four (4) conduit landing locations identified by ¼" diameter indentations in the upper left side and (2) on the middle right side of the enclosure (refer to Figure 4). It is the responsibility of the installer to determine the best location to punch for conduit knockouts.

4.3 Preparing Batteries for Installation



WARNING: BATTERIES ARE HEAVY. Each battery weighs approximately 96.5 lbs. (43.8kg). Two (2) persons lifting, and placement is strongly recommended to prevent personal injury.

Each battery is shipped in a separate package. Remove battery from its packaging and set upright near the installation location.

4.3.1 Battery Unique ID Setting

The battery has a 6-position dipswitch that requires adjustment prior to connecting to the NV14 Energy Storage System. The position of the four (4) left-most dipswitch pins determines the battery ID within the overall system. Each battery must have a unique ID. Dipswitches 5 & 6 are not to be used and should remain in the down OFF position.

The suggested dip switch settings are as follows:

NV14 Cabinet:

Battery 1 (position 2):

Pin 1	Pin 2	Pin 3	Pin 4	Pin 5	Pin 6		ID
ON	OFF	OFF	OFF	OFF	OFF		2

Battery 2 (position 3):

Pin 1	Pin 2	Pin 3	Pin 4	Pin 5	Pin 6		ID
OFF	ON	OFF	OFF	OFF	OFF		3

Battery 3 (position 4):

Pin 1	Pin 2	Pin 3	Pin 4	Pin 5	Pin 6		ID
ON	ON	OFF	OFF	OFF	OFF		4

Optional Battery Cabinet NV24:

Battery 4 (position 5):

Pin 1	Pin 2	Pin 3	Pin 4	Pin 5	Pin 6		ID
OFF	OFF	ON	OFF	OFF	OFF		5

Battery 5 (position 6):

Pin 1	Pin 2	Pin 3	Pin 4	Pin 5	Pin 6		ID
ON	OFF	ON	OFF	OFF	OFF		6

4.3.2 Battery Sleep Mode

Each battery is shipped in 'sleep mode' in which no voltage is present at the battery terminals. When a battery is in sleep mode, all indicators are unlit. If a battery 'wakes up' prior to installing, place it into sleep mode by pressing the reset button for 6 seconds. The battery reset button can be pressed using any thin, solid material (such as the end of a provided paper clip, see Figure 3).



Figure 3

5 Installation Requirements

5.1 Site Location and Prep

The NV14 Energy Storage System can be installed indoors, such as a garage, or outdoors mounted using a concrete, pre-formed pad, or pavers. The cabinet is a NEMA Type 3R rated cabinet suitable for outdoor use.

5.1.1 Cabinet Dimensions

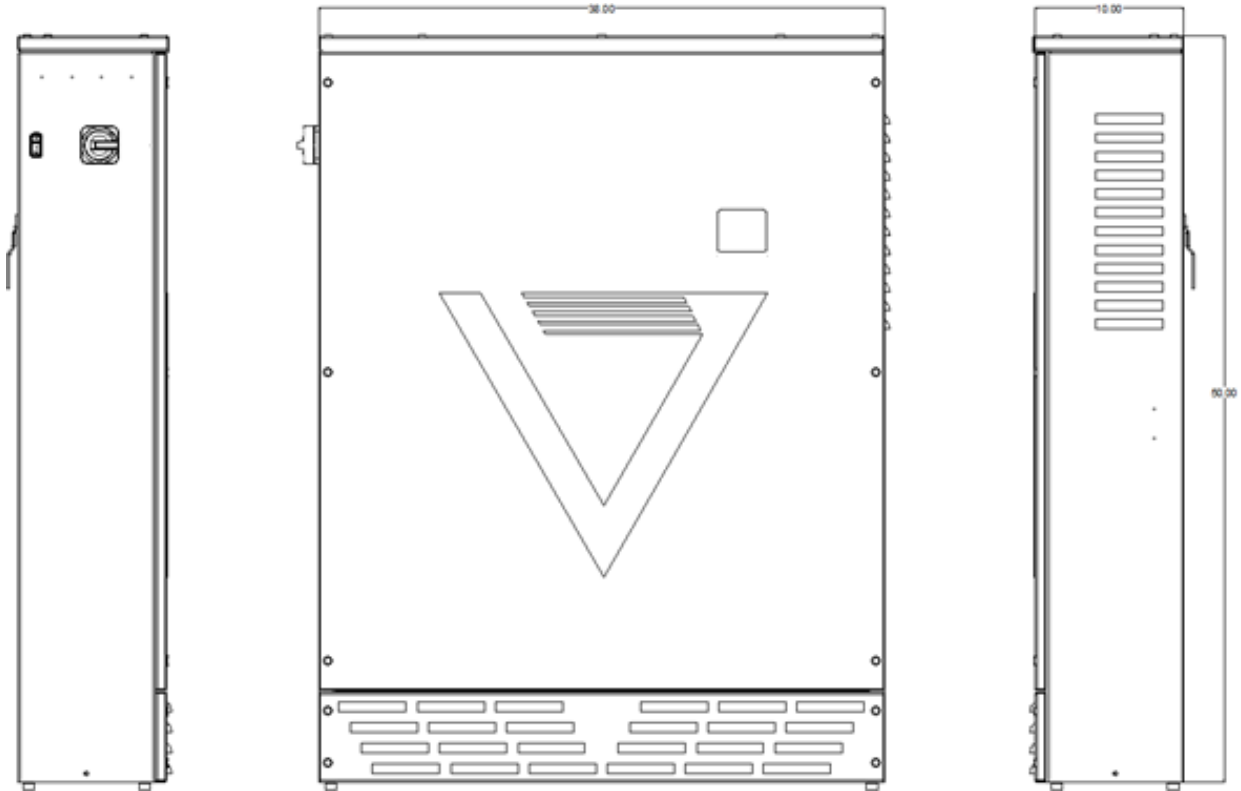
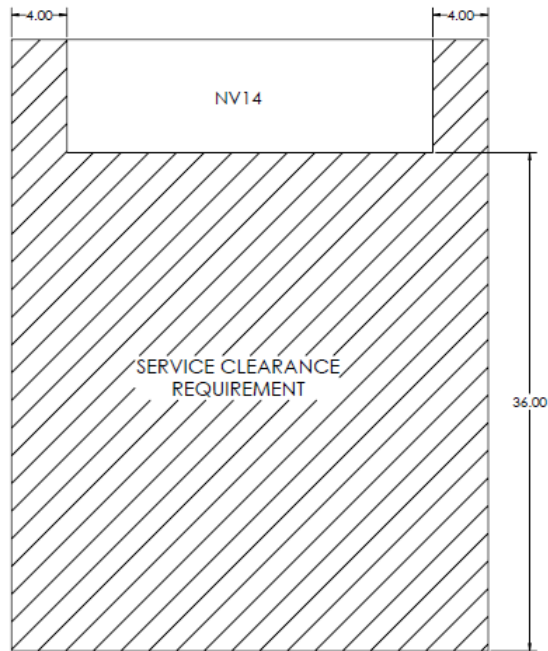

Figure 4

5.1.2 Clearance Requirements

The NV14 Energy Storage System requires clearance for cooling and service access. The cabinet must be installed with 4" clearance on right side, 4" on SW1 switch side and 36" clearance to the front. There is no vertical clearance requirement other than not to use the top as a shelf for storage (either temporary or permanent). NeoVolta is UL 9540A certified and has no clearance requirements for the batteries as there is no fire and no thermal runaway concerns. As such, NeoVolta can be installed within 4 inches of doors and windows per local AHJ requirements.



5.1.3 Critical Load Box

All installs must have a critical load box installed that consists of the basic loads needed in case of utility grid failure or power loss. The NV14 will provide power to the critical load box. All neutral wires for each critical load box breaker must be isolated from the main service panel and installed on the critical load box neutral bar. The critical load box neutral bar must be wired to the NV14 Output Load Neutral terminal block.



WARNING: Electrical installation in the United States shall be done in accordance with all local electrical codes and/or the National Electrical Code (NEC), ANSI/NFPA 70.



WARNING: Failure to install critical load box correctly could result in poor power quality (such as flickering lights) and possibly unsafe ground loops.

5.1.3.1 Critical Load Box Circuits

It is not possible to detail all possible loads that must be removed from the main service panel and installed on the critical load box. But some of the general guidelines to follow are:

- Refrigerator, small kitchen appliances, garage, home office with WiFi router, entertainment area (DVR and/or Television, and lighting circuits)
- All 120V receptacle circuits
- Any Low Power or Low Use circuits needed under emergency conditions

Do not include non-essential circuits that could drain batteries quickly such as:

- Air Conditioner
- Electric Dryer
- Electric Water Heater
- Pool and/or Jacuzzi
- 240V Electric Vehicle Charger
- Other 240V circuits



WARNING: When moving breakers to critical load box, do not split multi-wire circuits that share the same neutral. Either move both breakers with a shared neutral to the critical load box or do not move either one. Never move one breaker of a multi-wire circuit and not the other. Unsafe ground loops could occur, which may damage electrical equipment.

5.1.4 Indoor Location Preparation

The NV14 Energy Storage System must be installed on a rigid, flat level surface capable of supporting the full weight of the cabinet. If installed inside a garage, it may be necessary to raise the NV14 above the garage concrete sill to allow the NV14 to be placed flush against the garage wall. If a raised platform is used, it must be a level and sturdy enough to support the full weight of the NV14 (575lbs). The raised platform must extend beyond the NV14 cabinet by 3" on both sides and front (See figure 6).

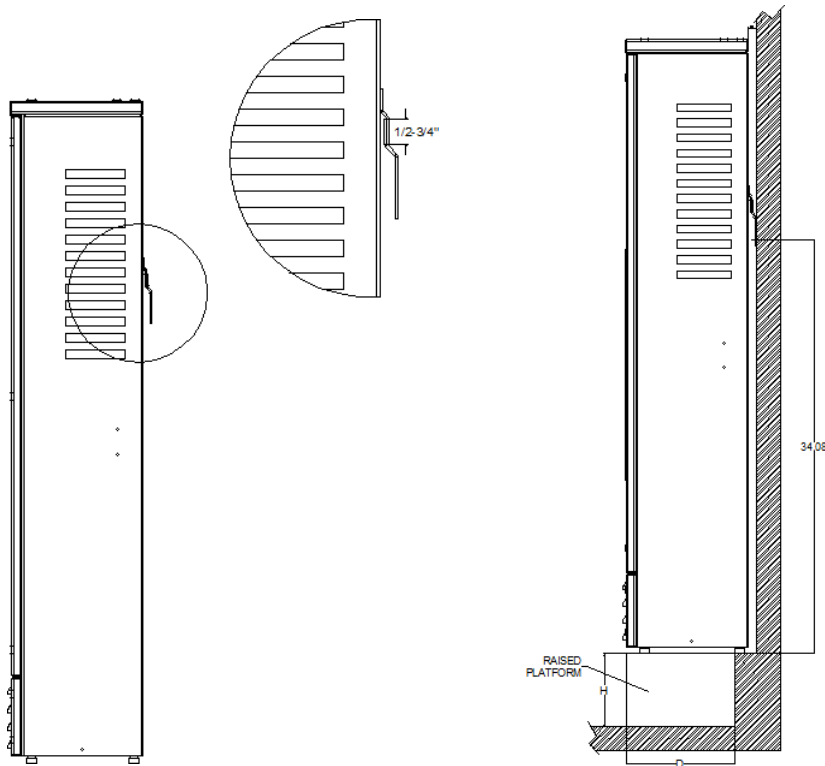

Figure 6

5.1.5 Outdoor Location Preparation

The NV14 Energy Storage System may be installed in an outdoor location against a wall – preferably under an eave. The NV14 Energy Storage System must not be installed on a south-facing or west-facing wall if routinely over 120° F to prevent possible overheating and a shortened battery life. If installed outside on south or west facing wall and ambient temperatures are routinely over 120° F, then shade the NV14 Energy Storage System.

The NV14 Energy Storage System must be installed on a rigid, flat level surface capable of supporting the full weight of the cabinet. A concrete surface, pre-cast concrete pad, or cement pavers are highly recommended. If using a pre-cast pad, the pad must be a minimum of 2" thick and overhang the cabinet by 3" on both sides and front.

Note: The NV14 Energy Storage System shall not be installed outside if above 2,500 ft in elevation or if more than two consecutive nights of below freezing temperatures, battery will not charge or discharge until it warms up, which can take a while.

5.1.6 Securing the NV14

The NV14 Energy Storage System must be installed using the wall mounting brackets and hardware provided. The wall mounting brackets must be anchored to a minimum of two (2) vertical wall studs (See figure 7). 3/8" x 2 1/2" lag bolts with washers must be used to mount the wall mounting bracket to the vertical studs. This bracket is not intended to support the weight of the NV14 or NV24. Instead, it is intended to prevent a tip-over hazard.

Position the Wall Mounting Bracket so that the top of the upper lip is approximately 1/2" - 3/4" higher than the cabinet mounting bracket lower lip (See figure 6). The cabinet is equipped with leveling feet for minor height adjustments as needed. A leveling foot adjustment tool is provided.

When an adequate installation site has been prepared, position the NV14 Energy Storage System cabinet in place against the wall. Lift the cabinet up a few inches to clear the wall mounting bracket. Lower the cabinet so that the cabinet mounting bracket mates with the wall mounting bracket. Adjust the leveling feet as needed to ensure that all four (4) leveling feet are touching the floor or concrete slab.



CAUTION: All four leveling feet must be firmly on the surface. Do not 'hang' the cabinet solely from the wall mounting bracket.

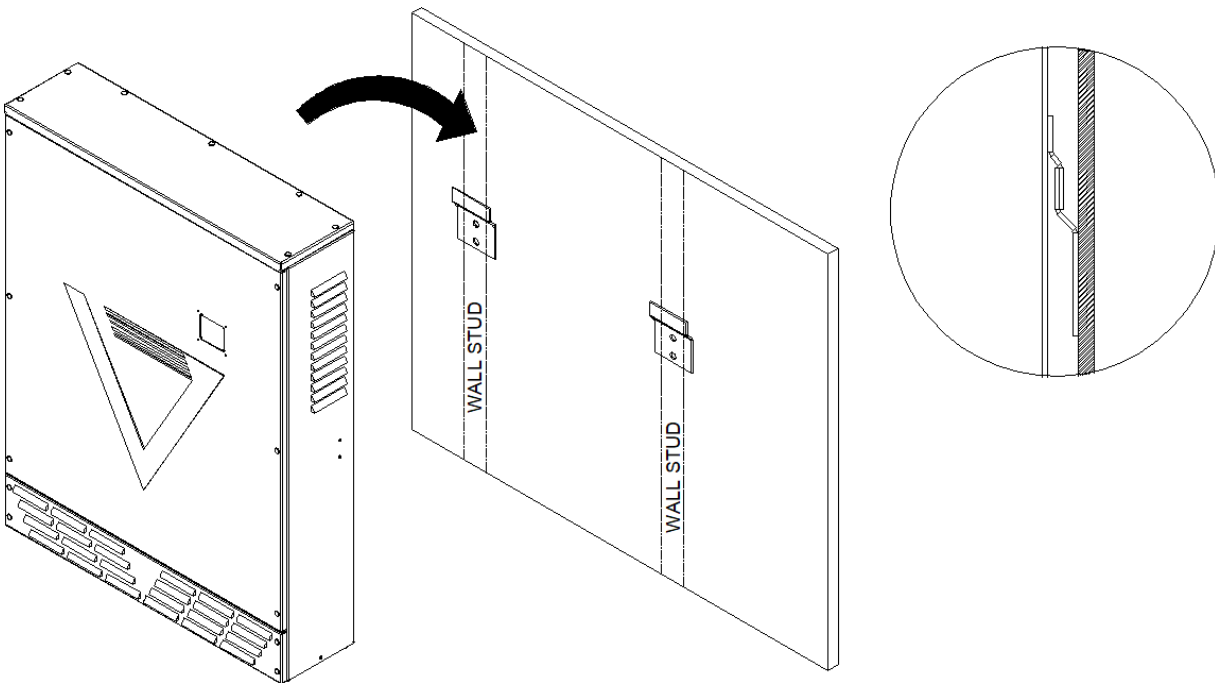

Figure 7

5.2 Optional Battery Cabinet Installation

5.3 Site Location and Prep

The NV24 Optional Battery Cabinet can be installed indoors, such as a garage, or outside on concrete, pre-formed pad, pavers or bricks. The cabinet is a NEMA 3R rated cabinet suitable for outdoor use.

5.3.1 Battery Cabinet Dimensions

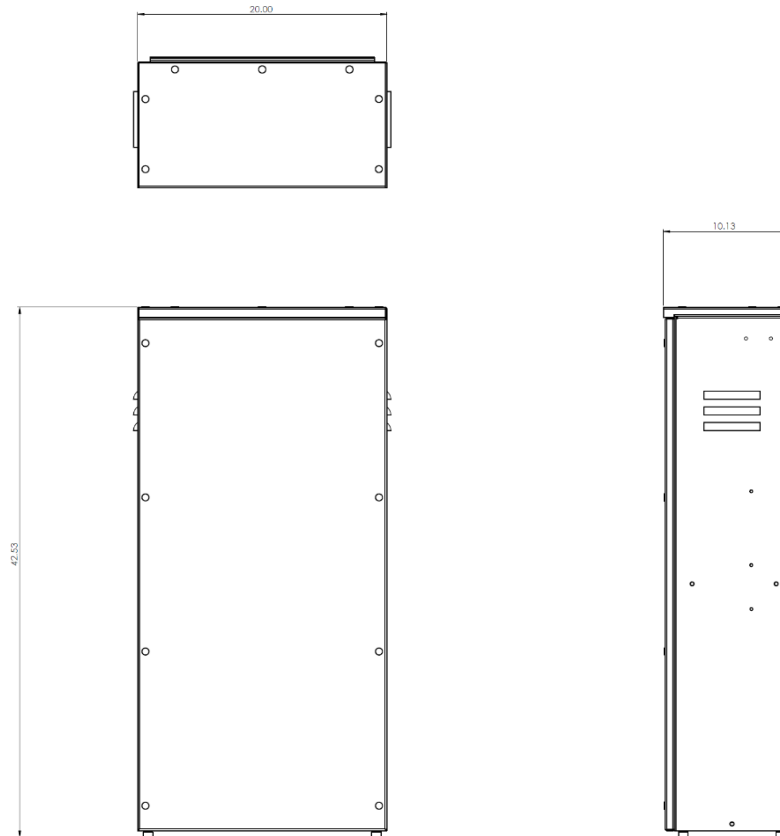

Figure 8

5.3.2 Location Preparation and Securing the Optional Battery Cabinet

The NV24 Optional Battery Cabinet must be installed in a similar fashion as the NV14. Refer to Sections 5.1.4 and 5.1.5.

The NV24 Optional Battery Cabinet must be installed using the wall mounting bracket and hardware provided. The wall mounting brackets must be anchored to a vertical wall studs similar to the installation of the NV14 (See figure 7). 3/8" x 2 1/2" lag bolts with washers must be used to mount the wall mounting bracket to the vertical studs. This bracket is not intended to support the weight of the NV14 or NV24. Instead, it is intended to prevent a tip-over hazard.

The NV24 Optional Battery Cabinet has four (4) conduit landing locations identified by 1/4" diameter indentations in the top right side and top left side of the enclosure (refer to Figure 8). It is the responsibility of the installer to determine the best location to punch for conduit knockouts.

5.3.3 Clearance Requirements

The NV24 Optional Battery Cabinet requires clearance for cooling and service access. The cabinet must be installed with 4" clearance on each side and 36" clearance to the front. There is no vertical clearance requirement other than not to use the top as a shelf for storage (either temporary or permanent). NeoVolta is UL 9540A certified and has no clearance requirements for the batteries as there is no fire and no thermal runaway concerns. As such, NeoVolta can be installed within 4 inches of doors and windows per local AHJ requirements.

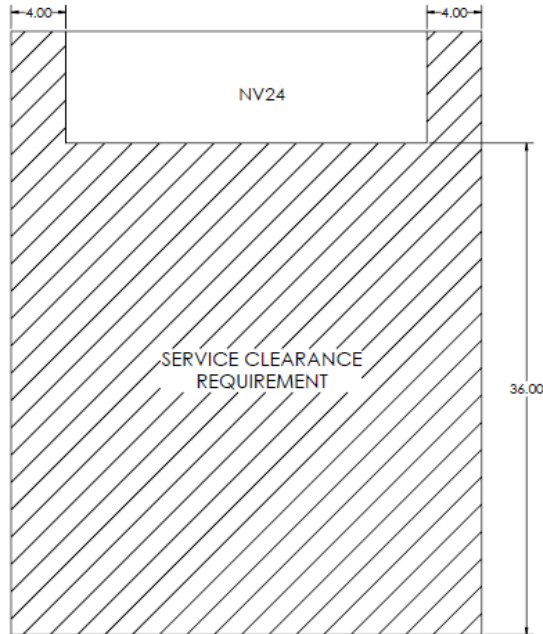

6 Electrical Connections

6.1 Wiring



WARNING: Verify all source power is OFF or disconnected prior to wiring the NV14 Energy Storage System



CAUTION: The following wiring information contains general wiring connections within the NV14 Energy Storage System. These instructions are not intended to describe all possible residential configurations. It is the responsibility of the NeoVolta authorized installer to determine the wiring requirements, codes, and safety standards at the specific site.

The NV14 Energy Storage System has three (3) possible input locations and one (1) output location. Allowed input sources are:

- Utility Grid: 120/240VAC split single phase with neutral
- DC PV: A maximum of four (4) DC PV inputs with each input protected with 20A fuses
- AC PV or Generator: 240VAC input. Either AC PV source or Generator Source is permitted but not both. Maximum AC PV input is 9,200 Watts.
- Output is 120/240VAC split phase with neutral (same as utility grid)
- With settings change, the NV14 can convert to 208V 3-phase power (contact NeoVolta for procedures)



WARNING: Verify the disconnect switch and all circuit breakers in the NV14 Energy Storage System are in the OFF position prior to making wiring connections.

6.1.1 Utility Grid Connection

Use copper wire only. The minimum wire size that can be used is 8AWG. The maximum wire size that will fit in the terminals is 6AWG. Connect the 120/240V wires from the utility to the top of TB1 (L1 & L2). Torque to 25 in-lb. (2,8Nm). Connect 120/240V neutral wire from the utility grid to the top of TB1. Torque to 25in-lb. (2,8Nm). Refer to Figure 10 below for location of TB1 wiring locations.

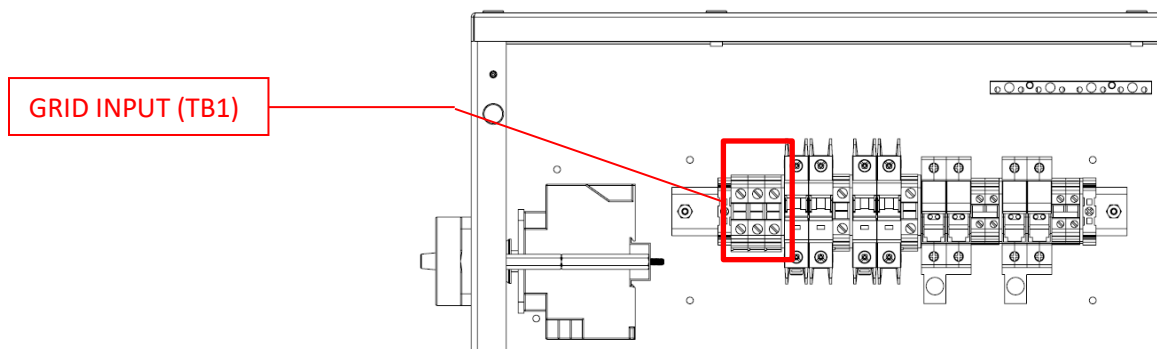

Figure 10

6.1.2 PV1, VDC Connection (PV2, VDC Connection, if present)

Use copper wire only. The minimum wire size that can be used is 10AWG. The maximum wire size that will fit in the terminals is 6AWG. Connect the PV1 '+' wires from the VDC PV source to the top of fuse F1 or F2. Torque to 25 in-lb. (2,8Nm). Connect the PV1 '-' wire from the VDC PV source to the top of TB4. Torque to 25 in-lb. (2,8Nm). Refer to Figure 11 below for location of PV fuses and terminal wiring locations. The NV14 has 2 MPPTs. Each MPPT can accept up to 500V, 26A, and 5,000W. There are four (4) DC input fuses (two per MPPT). Each fuse can accommodate 1 string of DC PV up to 2,500W, 500V and 20A.

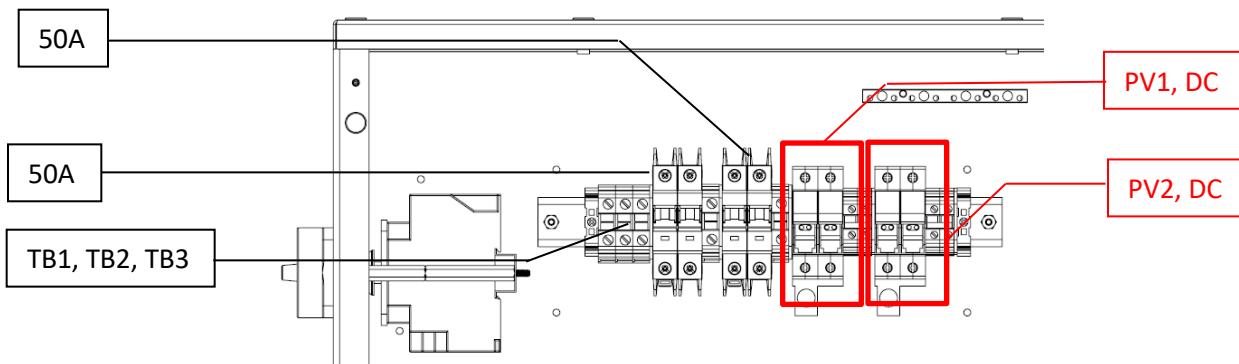

Figure 11

6.1.3 PV, VAC Connection or Generator Connection

Use copper wire only. The minimum wire size that can be used is 8AWG. The maximum wire size that will fit in the terminals is 6AWG. Connect the 120/240V wires from the VAC PV source to the top of CB2. Torque to 25 in-lb. (2,8Nm). Connect 120/240V neutral wire from the VAC PV source (if present) to the top of TB2. Torque to 25 in-lb. (2,8Nm). Refer to Figure 12 below for location of CB2 and TB2 wiring locations. 9,200 W of AC PV is the maximum allowed.

Note: An external generator can be installed at CB2 and TB2 if desired. When generator source is installed, VAC PV source is not allowed.

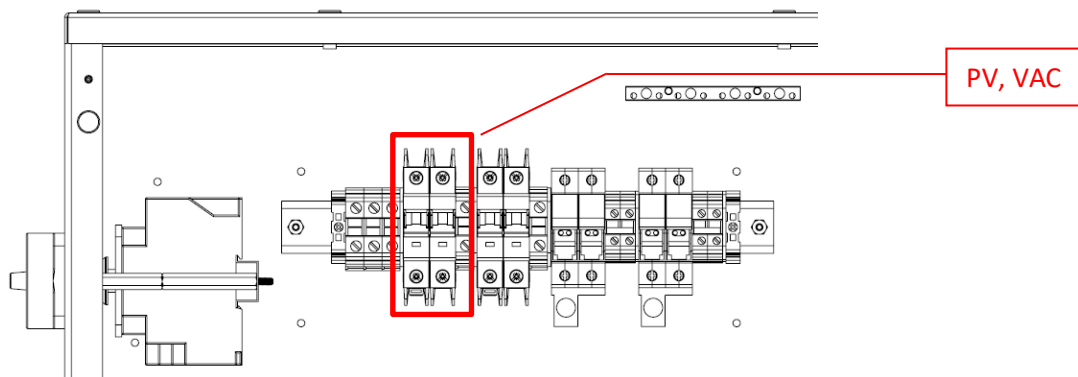

Figure 12

6.1.4 Output Connection

Use copper wire only. The minimum wire size that can be used is 8AWG. The maximum wire size that will fit in the terminals is 6AWG. Connect the output wires at the top of CB3. Torque to 25 in-lb. (2,8Nm). Connect the output neutral wire at the top of TB3. Torque to 25 in-lb. (2,8Nm). Refer to Figure 13 below for location of CB3 and TB3 wiring locations.

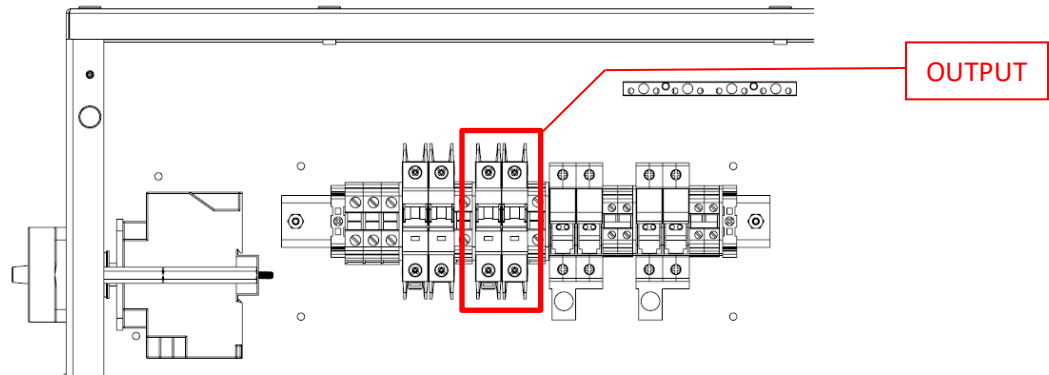

Figure 13

6.1.5 Optional Battery Connection

The battery cabinet, NV24, comes with 4AWG wire. Connect the wire to the output terminals on the battery cabinet. Torque to 32 in-lb. (3,7Nm). See figure 14.

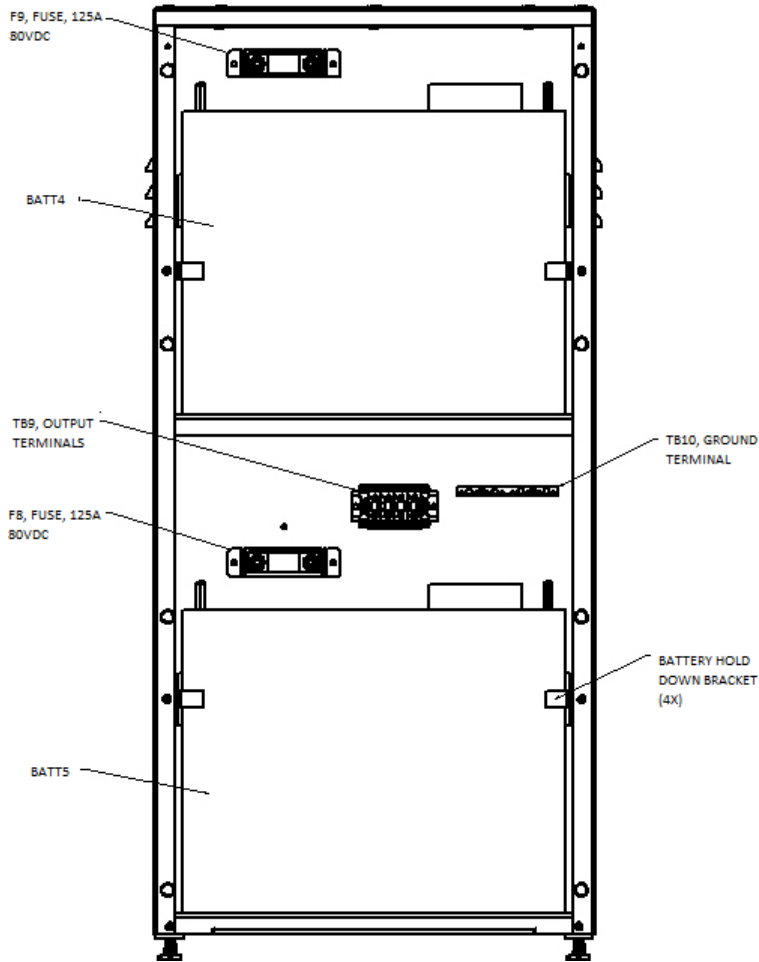

Figure 14

Route the wires to the left or right as required by the placement of the battery cabinet with respect to the NV14. The minimum wire size that can be used is 4AWG. The length of wire provided is the longest allowed.

Connect the two (2) red (+) wires to the NV14 fuse bar as shown in figure 15. Tighten to 90 in-lbs.

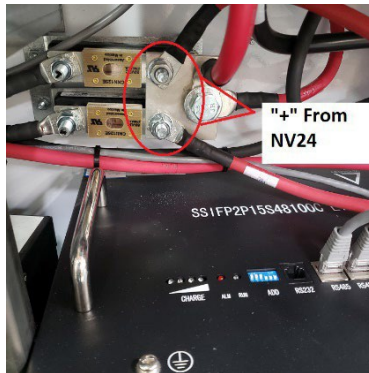

Figure 15

Connect the two (2) black (-) wires to the negative terminals as shown in figure 16. Tighten to 18 ft-lbs.

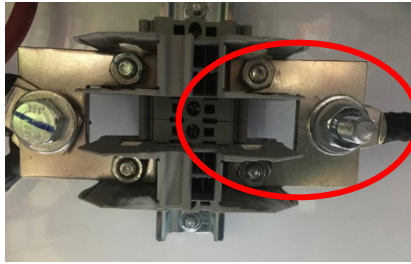

Figure 16

Note: it may be necessary to remove the din rail assembly of the negative terminals to tighten the battery wires to the terminals. If needed, remove the din rail from the back of the NV14 at the two (2) mounting screws.

Connect the ground wire to the NV14 ground terminal. Route the wire and secure using wire ties provided.

Connect the CAT5 ethernet cable to the top battery in the NV14. Route the cable and secure using wire ties provided.

6.2 Battery Installation

There are three (3) batteries that are supplied with the NV14 Energy Storage System. They are supplied separately and need to be physically installed and wired. The batteries are shipped in 'sleep mode'. Batteries in sleep mode do not have any live voltage on the terminals. When a battery is in sleep mode, all indicators are unlit. If a battery 'wakes up' prior to installing, place it into sleep mode by pressing the reset button for 5 seconds. The battery reset button can be pressed using any thin, solid material (such as the end of a provided paper clip, see Figure 17).



Figure 17



WARNING: BATTERIES ARE HEAVY. Each battery weighs approximately 96.5 lbs. (43.8kg). Two (2) person lifting and placement is strongly recommended to prevent personal injury.

The NV14 Energy Storage System is supplied with battery brackets to keep batteries securely in place after installation. The brackets are installed and must be removed prior to placing batteries and re-installed after battery placement.



WARNING: To protect against cabinet damage, do not operate the NV14 Energy Storage System without battery brackets properly installed.

6.2.1 Battery 1 Installation Instructions

- Remove upper battery hold down bracket (see figure 18)
- Lift battery up onto battery shelf
- Push battery flush against the back of the cabinet and slide battery to the left until battery is behind left side enclosure lip. Be careful not to ‘pinch’ battery wires between battery and cabinet. It is suggested to place the battery wires across the top of the battery with the terminals outside the cabinet.
- Replace upper battery hold down bracket

Note: Do not connect terminal wiring at this time. Note the wire terminal lug has a protective cover. Do not remove until ready to wire the batteries at a later step in the installation process.

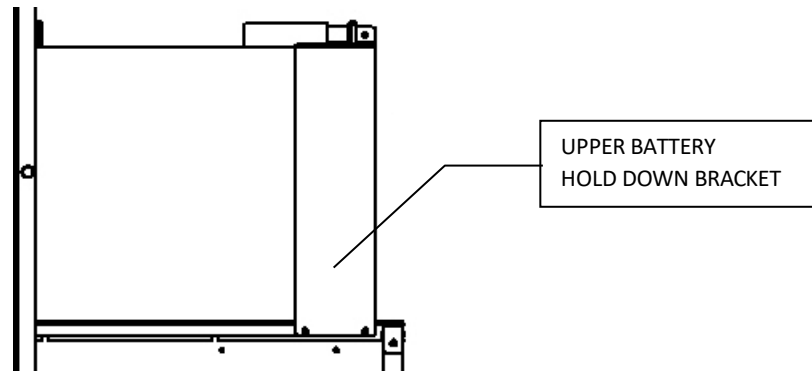

Figure 18

6.2.2 Battery 2 and 3 Installation

- Lift each battery up onto cabinet base.
- Push battery flush against the back of the cabinet and slide battery to the respective side until battery is behind side enclosure lip. Be careful not to ‘pinch’ battery wires between battery and cabinet. It is suggested to place the battery wires across the top of the battery with the terminals outside the cabinet
- Do not replace lower battery hold down bracket at this time. Set bracket and hardware aside and install after battery wiring steps are completed.

Note: Do not connect terminal wiring at this time. Note the wire terminal lug has a protective cover. Do not remove until ready to wire the batteries at the next step in the installation process.

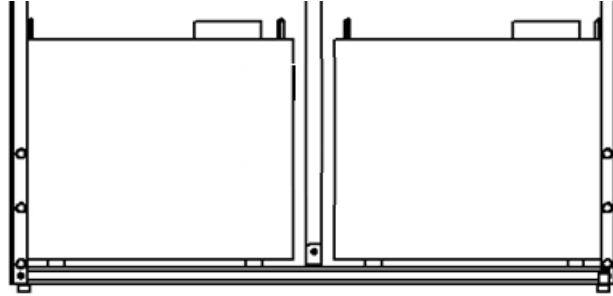

Figure 19

6.2.3 Battery 4 and 5 Installation (Optional Battery Cabinet)

- Lift each battery up into cabinet. Battery 4 on the top shelf and Battery 5 on the bottom.
- Push battery flush against the back of the cabinet. Be careful not to ‘pinch’ battery wires between battery and cabinet. It is suggested to place the battery wires across the top of the battery with the terminals outside the cabinet.
- Rotate battery hold down brackets 90 degrees so that the bracket is against the face of the battery. Tighten bracket in place (see figure 14). Both NV24 batteries have these brackets on both sides of the batteries.

6.3 Battery Wiring Connections

- Remove battery terminal cover and set aside.
- Connect the black battery wire to each battery negative terminal using the terminal hardware provided with each battery. Each battery has two (2) terminals marked as ‘-’. Either terminal is acceptable to install the black battery wire. Torque the battery terminal to 160 in-lbs. (18Nm).
- Connect the red battery wire to each battery positive terminal using the terminal hardware provided with each battery. Each battery has two (2) terminals marked as ‘+’. Either terminal is acceptable to install the red battery wire. Torque the battery terminal to 160 in-lbs. (18Nm).
- Connect the CAT5 ethernet cable to the battery RS485 port. There are two (2) RS485 ports. The upper battery has one (1) CAT5 cable to install. Either RS485 port on the battery is acceptable. The lower batteries have two (2) CAT5 cables to install in each of the RS485 ports.
- Replace battery terminal covers.

Note: To install wiring on lower batteries, it is necessary to slide the batteries out from the cabinet approximately 3” - enough to expose the battery terminals. Do not slide battery all the way out of the cabinet as the battery wiring will not be long enough.

- Push the lower batteries back into the cabinet flush against the back of the cabinet and slide battery is behind enclosure lip. Be careful not to ‘pinch’ battery wires.
- Install the lower battery hold down bracket previously removed.
- If Optional Battery Cabinet is installed, connect wiring to battery 4 and 5 as noted above.
- If Optional Battery Cabinet is installed, connect CAT5 ethernet cable to the RS485 port on the battery as noted above.

7 Operation

7.1 Applying Power

Apply power in the following step-by-step procedure. Do not advance to the next until the current step has been properly verified.

1. Verify all internal circuit breakers (CB1, CB2, CB3) are in the OFF position.
2. Verify the NV14 Energy Storage System disconnect switch is in the OFF position.
3. Verify the NV14 Energy Storage System inverter disconnect switch is in the OFF position
4. Verify the NV14 Energy Storage System inverter DC Bus switch is in the OFF position (depressed)
5. Turn on the tandem 40 A grid power breaker at the feeder breaker panel.
6. Turn on NV14 Energy Storage System disconnect switch.
7. Wake up the upper battery (Batt1) by using a small rigid pin (such as the end of provided paper clip) This will wake up all connected batteries in the NV14 and/or NV24. If all batteries do not automatically turn on, then turn each one on manually.
8. Verify proper voltage is present at the Utility Grid circuit breaker '+N' (top) within the cabinet.
9. Turn on NV14 Energy Storage System inverter switch. Push in the "Green" ON button (press in)
10. Within approximately 5 seconds, the NV14 Energy Storage System LCD screen should turn on. The AC grid LED should be illuminated. It takes Three minutes for the "Normal" LED to come on.
11. Use a voltmeter to verify the battery voltage is between 47 and 51 VDC (Nominal 48VDC).
12. Verify green charge lights are lit and the green Run light is slowly flashing.
 - a. Batteries are now live. Replace battery terminal covers previously removed. It is important that battery terminal covers are in place to avoid accidental contact with the battery terminals.
13. Verify voltage is present at the bottom of the output circuit breaker.
14. Once the Normal LED light illuminates, flip up/on the output circuit breaker.
15. IF AC PV is installed, flip up/on the AC PV input breaker.
16. IF DC PV is installed, push closed the DC PV fuse blocks.
17. The entire system is now live.
18. Verify the inverter settings are correct (refer to Settings Section for guidance).

8 System Settings

All system settings are performed on the internal inverter at the LCD screen. The LCD screen is accessible by removing the front cover.



WARNING: Only a NeoVolta authorized installer is allowed to configure or adjust the system settings. Contact NeoVolta for a list of Authorized installers in your region.

All system settings are passcode protected. An authorized NeoVolta installer has the passcode and can adjust the system settings.

The following sections describe the available NV14 Energy Storage System settings, the functional behavior, and the factory default settings.

8.1 Operation and Display Panel

The Operation and Display Panel consists of four (4) indicators across the top, four (4) function keys at the bottom, and an LCD display that indicates the operating status and the input/output power information (Figure 20).

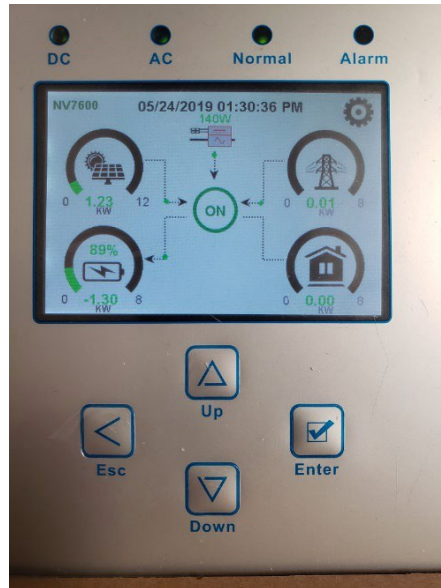

Figure 20

Table 1, shown below, lists the indicator LED status. Table 2, shown below, lists the function key action.

Table 1

	LED Indicator	Status
DC	Green LED Solid Light	DC PV Connection Normal
AC	Green LED Solid Light	AC Grid Connection Normal
Normal	Green LED Solid Light	Inverter Operating Normal
Alarm	Red LED Solid Light	Malfunction or Warning

Table 2

Function Key	Action
Esc	Exit setting mode
Up	Go to previous selection or increase value of selected box
Down	Go to next selection or decrease value of selected box
Enter	Confirm selection or save screen values before exiting

8.2 LCD Display Icons

8.2.1 Main Screen

The LCD Main Screen is a touchscreen display. The image below, Figure 21, shows the overall information of the NV14 Energy Storage System.

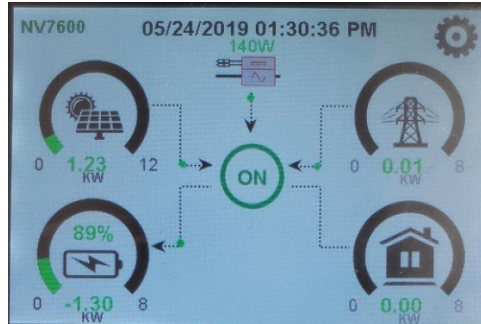





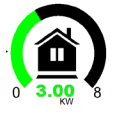
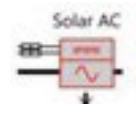



Figure 21

8.2.1.1 Features of the Main Screen

-  Indicates system operating normally. If it displays a red “X” then the system has an error. An error code will display underneath the icon. Refer to Appendix for error codes. If the icon is an “up” green arrow, the firmware is being upgraded.
-  System Setup Icon. Pressing this to enter into the system setup screen which includes Basic Setup, Battery Setup, Grid Setup, System Alarms and Li-Batt info. An alternate method to enter System Setup is to press the ‘Enter’ button.
-  PV Power, DC. Value shown for illustrative purposes only. Arrows always shown flowing away from icon indicating DC PV Solar providing power to NV14 Energy Storage System. Power value shown is always positive.
-  Battery Power and Charge level. Values shown for illustrative purposes only. When arrows shown flowing away from icon, it indicates batteries are providing power to NV14 Energy Storage System and power value is positive. When arrows shown flowing into icon, it indicates batteries are being charged and power value is negative.
-  Grid Power. Values shown for illustrative purposes only. When arrows shown flowing away from icon, it indicates utility is providing power to NV14 Energy Storage System and power value is positive. When arrows shown flowing into icon, it indicates the system is selling to the main service panel and/or grid. Power value is negative.
-  Load Power. Value shown for illustrative purposes only. Arrows always shown flowing into icon indicating NV14 Energy Storage System is providing power to loads.
-  AC PV (String or Micro inverter). Value shown for illustrative purposes only. Arrows always shown flowing away from icon indicating AC PV Solar providing power to NV14 Energy Storage System. Power value shown is always positive. This icon may show small 5-20 watts of current flow even when the sun is not out as this value reflects the NV14 safe grid signal.

8.2.2 System Setup Menu

The system setup menu is accessed by pressing the System Setup icon  on the Main Screen. The System Setup screen is shown below.

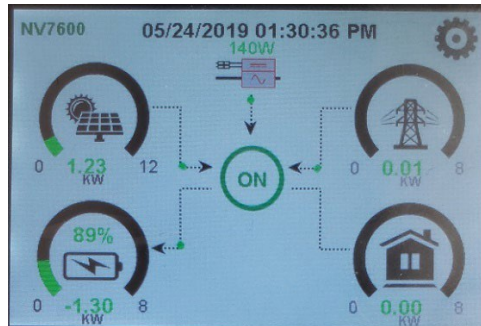

The System Setup screen displays the seven (7) sub screens. The seven (7) sub screens are Basic Setting, Battery Setting, System Work Mode, Grid Setting, Gen Port Use, Advanced Functions, and Device Info

When making any changes on any screen, the [OK] button must be selected, or the changes will not take effect. Changing screens either by selecting another tab or by selecting [Cancel] or the ESC key, will not save any changes.

8.2.2.1 Basic Setting

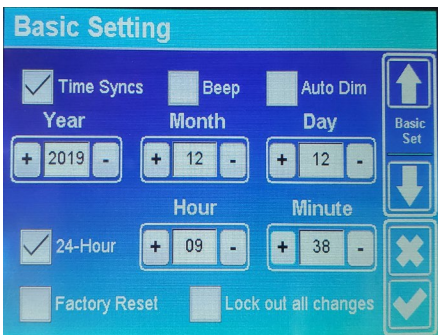

- Beep: Audible sound when system has a fault.
- Auto Dim: Will turn off LCD screen after number of seconds chosen (when box is checked).
- 24 Hour: 24-hour display
- Hour/Minute: Time of Day
- Factory Reset: Resets all inverter settings to original factory settings
- Lock Out: Prevents any settings changes. Requires password.

Factory default:

- Beep: Not selected.
- Auto Dim: Not selected
- 24 Hour: Selected
- Time of Day: Set to Pacific Standard Time (does not allow for daylight savings)
- Factory Reset: Not selected
- Lock Out: Selected. Requires password to unselect to make settings changes.

8.2.2.2 Battery Setting

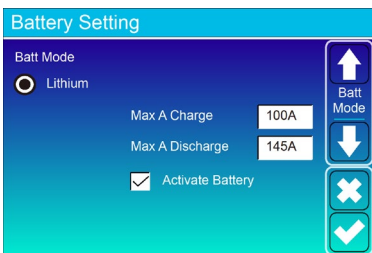

Factory default:
 Batt Mode: Lithium
 Max A Charge: 100A
 Max A Discharge: 145A
 Activate Battery: Selected

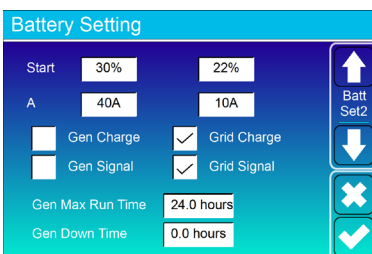

Factory default:
 Start %: 22%
 A: 10A
 Grid Charge: Selected
 Grid Signal: Selected
 Gen Max Run Time: 24-hours
 Gen Down Time: 0-hours

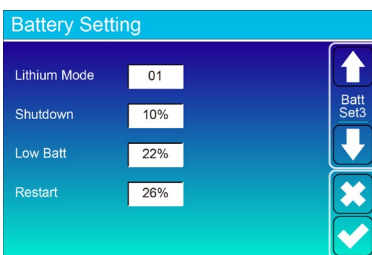

Factory default:
 Lithium Mode: 01 (do not change)
 Shutdown: 10% (Battery % inverter will shut down)
 Low Batt: 22%
 Restart: 26% (Battery % inverter will start charging, if possible)

8.2.2.3 System Work Mode

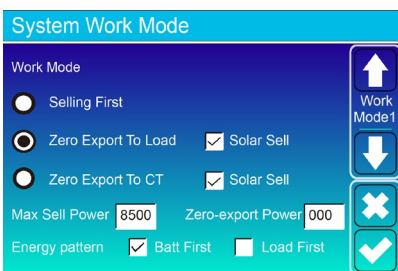

Factory default:
 Selling First: Unselected.
 Zero Export to Load: Selected
 Solar Sell: Checked
 Zero Export To CT: Not Selected
 Solar Sell: Checked
 Max Sell Power(W): 8500W
 Energy Pattern Batt First Selected

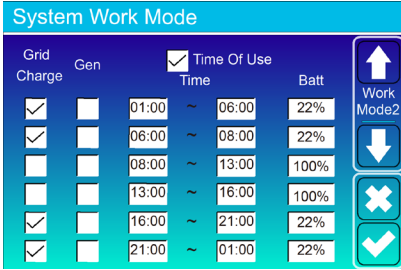

Factory default:

Time of Use: Checked.

Time Chart:

22%: Level battery will stop discharging. Note: Utility rates highest from 16:00 to 21:00 and batteries will be discharging during this time.

100%: Level Solar will charge battery to before providing power to load or grid sell.

8.2.2.4 Grid Setting

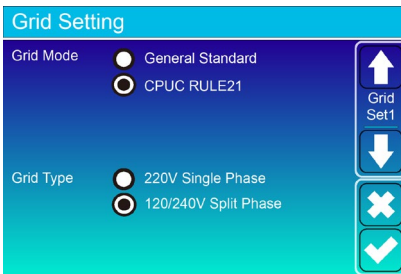

Factory default:

Grid Mode: CPUC RULE21 Selected.

Grid Type: 120/240V Split Phase Selected

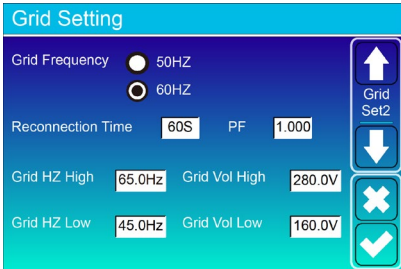

Factory default:

Grid Frequency: 60Hz

Reconnection Time: 60s.

PF: 1.000

Grid Hz High: 65.0Hz

Grid Vol High: 280.0V

Grid Hz Low: 45.0Hz

Grid Vol Low: 160.0V

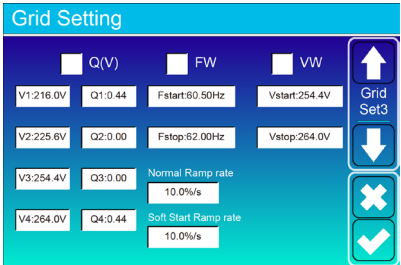

Factory default:

Q(V): Not Selected

FW: Not Selected

VW: Not Selected

All other values to be as shown. Do not Change

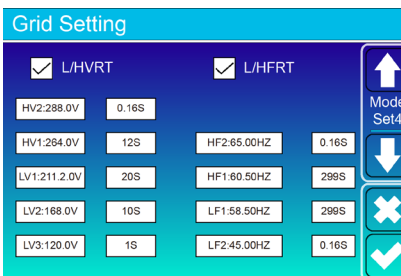

Factory default:

L/HVRT: Selected

L/HFRT: Selected

All other values to be as shown. Do not Change

8.2.2.5 Gen Port Use

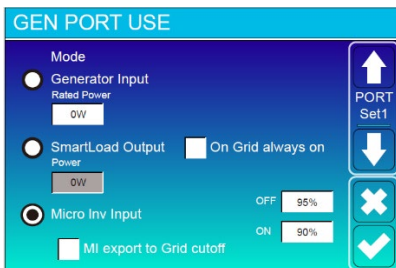

Factory default:

Micro Inv Input: Selected (unselect if no microinverters connected)

Gen Port use OFF: 95%

Gen Port Use ON: 90% (When Grid OFF, Battery level that Solar AC will start to charge batteries if excess Solar AC is available. Otherwise, Battery will power load)

8.2.2.6 Advanced Functions

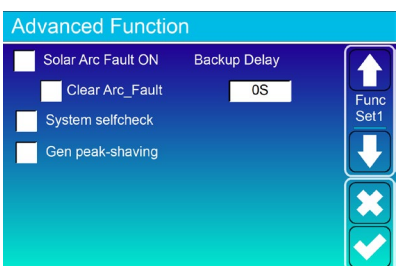

Factory default:

Solar Arc Fault ON: Not Selected

Clear Arc Fault: Not Selected

System selfcheck: Not Selected

Gen peak-shaving: Not Selected

8.2.2.7 Device Info

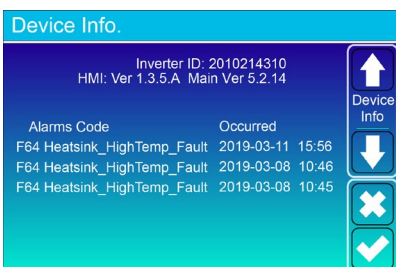

Device Info:

Shows history of faults

Shows LCD firmware version 1.3.5.A

Shows Inverter firmware version 5.2.1.4

9 Setup Wi-Fi Data Logger

Please refer to the Solarman App setup Instructions (shipped separately with this manual)

10 Installing Front Covers

1. Install lower front cover (see Figure 22).
2. Install upper front cover by placing mounting screws on top location then on bottom location and lastly on the middle location. Place screw caps on each mounting location (see Figure 22).
3. Once everything has checked out, place white screw caps on each front mounting location (10 places as shown in Figure 22).

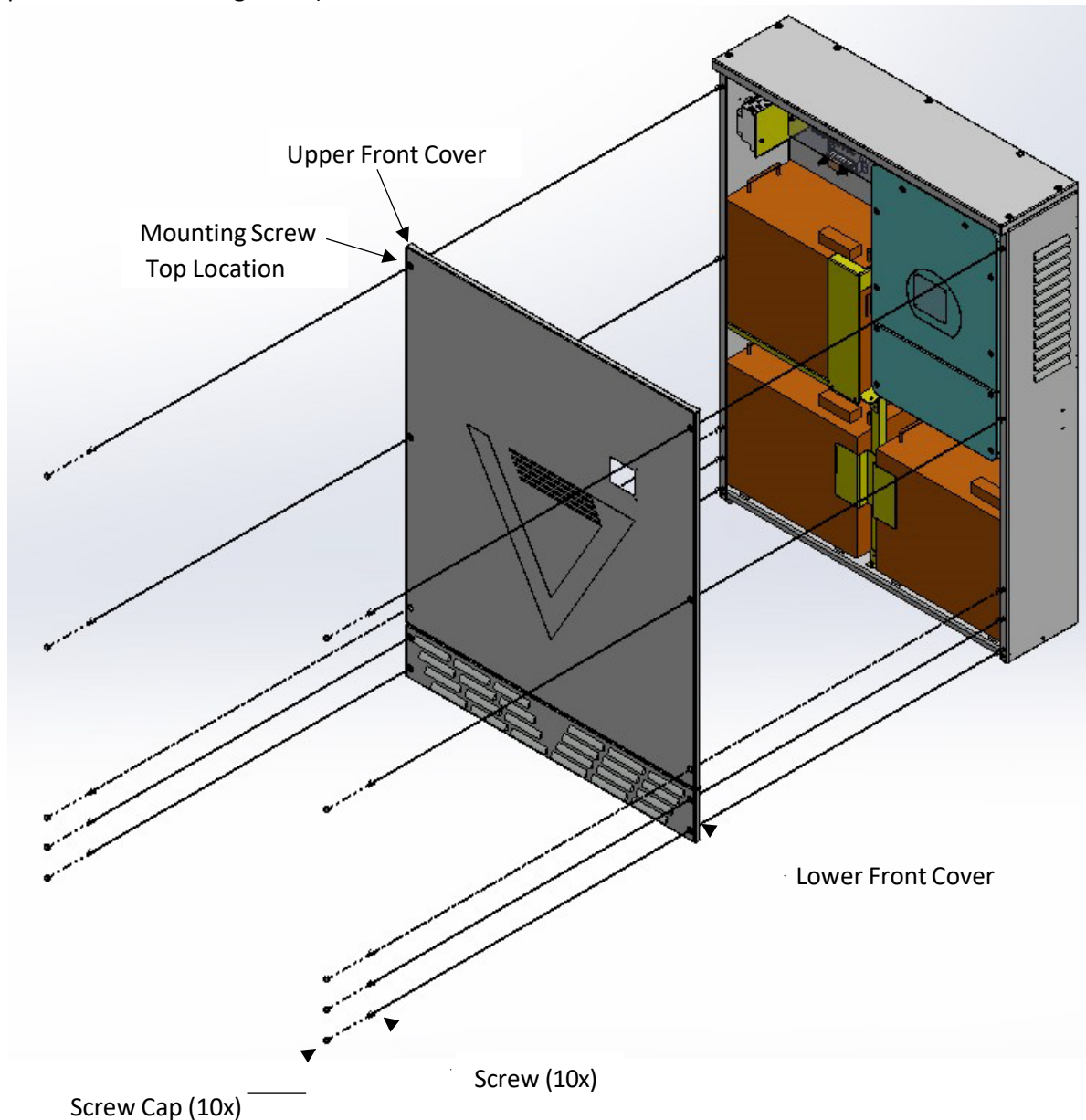

Figure 22

11 Specifications

SOURCE	SPECIFICATION	UNITS	VALUE
UTILITY	Voltage	VAC	120/240 Split phase
	Current	AAC	32A
	Frequency	Hz	57.0 – 62.0
	Circuit Protection	--	40A 2-pole circuit breaker
PV1, DC	Voltage	VDC	370 (range 125-500)
	Current	ADC	26A
	Power	W	8,448
	Circuit Protection	--	20A Fuse (x2)
PV2, DC	Voltage	VDC	370 (range (125-500)
	Current	ADC	26A
	Power	W	8,448
	Circuit Protection	--	20A Fuse (x2)
PV, AC (GENERATOR OPTIONAL)	Voltage	VAC	240
	Current	AAC	32A (9,200 W AC PV maximum)
	Frequency	Hz	45.0 – 65.0
	Circuit Protection	--	50A 2-pole circuit breaker
BATTERY PACK, CHARGING	Voltage	VDC	
	Current, nominal	ADC	60
	Current, max	ADC	100
	Capacity	Ah	300
	Type	--	Li-Fe-PO4
	Protection (+)	--	125A, 80VDC Fuse
BATTERY PACK, DISCHARGE	Voltage	VDC	42-58, 48 nominal
	Current, nominal	ADC	54
	Current, max	ADC	100
	Capacity	Ah	300 (NV14) 500 (NV24)
	Type	--	Li-Fe-PO4
	Protection (+)	--	125A, 80VDC Fuse
OUTPUT	Voltage	VAC	120/240 Split phase
	Current	AAC	32A
	Frequency	Hz	45.0 – 65.0
	Circuit Protection	--	50A 2-pole circuit breaker
ENVIRONMENT	Enclosure Rating	--	NEMA 3R
	Dimensions (NV14)	in (mm)	50H x 38W x 10D (1270 x 965 x 25)
	Dimensions (NV24)	In (mm)	42H x 20W x 10D (1080 x 508 x 25)
	Temperature, Min	C (°F)	-25 (-13)
	Temperature, Max	C (°F)	60 (140), derating >45C (113)
	Weight	lbs (kg)	NV14 575 (260) / NV24 270 (122)
COMPLIANCE	NV14		CAN/UL-9540:2016
	Inverter, NV7600		UL1741 Third Edition SB, IEEE1547, FCC 15 Class B, UL1699B
	Battery	Ah	UL1741, IEEE1547-2018, FCC 15 CLASS B, UL1699B, UL 9540A

12 Technical Reference

	SPECIFICATION	UNITS	VALUE
TORQUE	Utility Input, CB1	In-lb	25
	Utility Input, TB1	In-lb	25
	PV, DC Input, F1-F4	In-lb	25
	PV, DC Input, TB4-TB5	In-lb	25
	PV, AC Input, CB2	In-lb	25
	PV, AC Input, TB2	In-lb	25
	Output, CB3	In-lb	25
	Output, TB3	In-lb	25
	Ground Bar, TB6	In-lb	25
WIRE SIZES	Utility Input	--	8 AWG Cu, 75C, 600V
	PV, DC Input	--	8 AWG Cu, 75C, 600V
	PV, AC Input	--	8 AWG Cu, 75C, 600V
	Output	--	8 AWG Cu, 75C, 600V
	Ground	--	8 AWG Cu, 75C, 600V
FUSES	PV, DC Input	--	20A, 600VDC, Littelfuse SPF or UL listed equivalent
	Battery	--	125A, 80VDC, Littelfuse CNN_E or UL listed equivalent

13 Contact Information

For all service installation questions, please contact NeoVolta Operations

Phone: (858) 218-5942

Hours: Mon-Fri, 8am-5pm Pacific

14 Appendix 14.1 Schematic

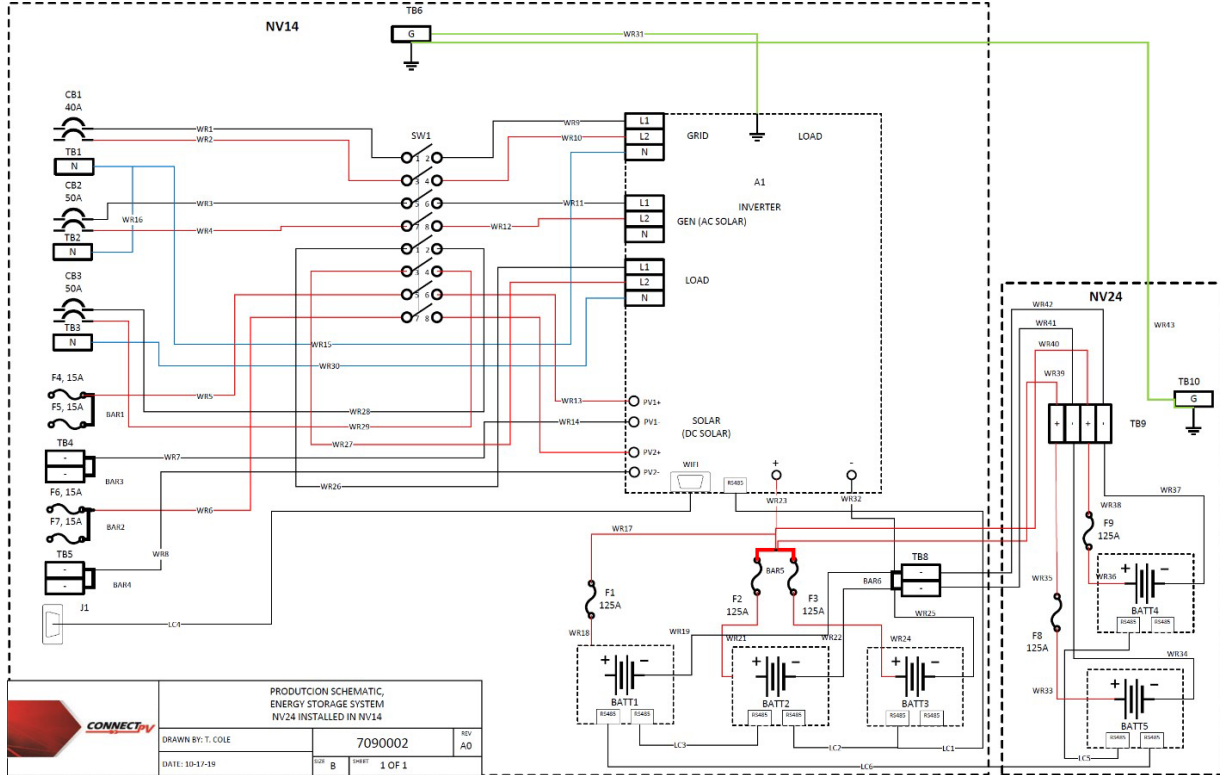

14.2 Fault Messages

Fault Code	Failure Mode	Fault Code	Failure Mode
F01	DC_Inversed_Failure	F33	AC_OverCurr_Fault
F02	DC_Insulation_Failure	F34	AC_Overload_Fault
F03	GFDI_Failure	F35	AC_NoUtility_Fault
F04	GFDI_Ground_Failure	F36	AC_GridPhaseSeque_Fault
F05	EEPROM_Read_Failure	F37	AC_Volt_Unbalance_Fault
F06	EEPROM_Write_Failure	F38	AC_Curr_Unbalance_Fault
F07	GFDI_Fuse_Failure	F39	INT_AC_OverCurr_Fault
F08	GFDI_Relay_Failure	F40	INT_DC_OverCurr_Fault
F09	IGBT_Failure	F41	AC_WU_OverVolt_Fault
F10	AuxPowerBoard_Failure	F42	AC_WU_UnderVolt_Fault
F11	AC_MainContactor_Failure	F43	AC_VW_OverVolt_Fault
F12	AC_SlaveContactor_Failure	F44	AC_VW_UnderVolt_Fault
F13	Working_Mode_change	F45	AC_UV_OverVolt_Fault
F14	DC_OverCurr_Failure	F46	AC_UV_UnderVolt_Fault
F15	AC_OverCurr_Failure	F47	AC_OverFreq_Fault
F16	GFCI_Failure	F48	AC_UnderFreq_Fault
F17	Tz_COM_OC_Fault	F49	AC_U_GridCurr_DcHigh_Fault
F18	Tz_Ac_OverCurr_Fault	F50	AC_V_GridCurr_DcHigh_Fault
F19	Tz_Integ_Fault	F51	AC_W_GridCurr_DcHigh_Fault
F20	Tz_Dc_OverCurr_Fault	F52	AC_A_InductCurr_DcHigh_Fault
F21	Tz_GFDI_OC_Fault	F53	AC_B_InductCurr_DcHigh_Fault
F22	Tz_EmergStop_Fault	F54	AC_C_InductCurr_DcHigh_Fault
F23	Tz_GFCI_OC_Fault	F55	DC_VoltHigh_Fault
F24	DC_Insulation_Fault	F56	DC_VoltLow_Fault
F25	DC_Feedback_Fault	F57	AC_BackFeed_Fault
F26	BusUnbalance_Fault	F58	AC_U_GridCurr_High_Fault
F27	DC_Insulation_ISO_Fault	F59	AC_V_GridCurr_High_Fault
F28	DCIOver_M1_Fault	F60	AC_W_GridCurr_High_Fault
F29	AC_AirSwitch_Fault	F61	AC_A_InductCurr_High_Fault
F30	AC_MainContactor_Fault	F62	AC_B_InductCurr_High_Fault
F31	AC_SlaveContactor_Fault	F63	ARC_Fault
F32	DCIOver_M2_Fault	F64	Heatsink_HighTemp_Fault

QUICK INSTALL

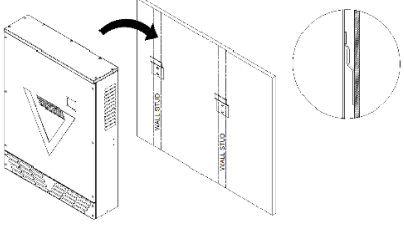
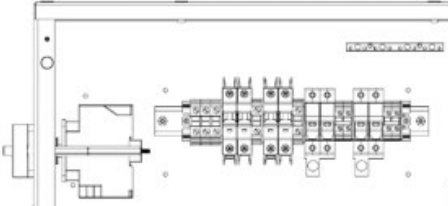
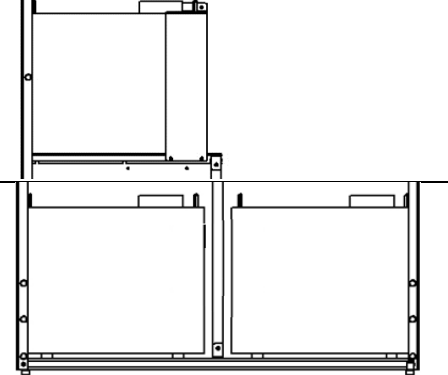
	<p>Mount NV14 in indoor or outdoor in secure location. Use mounting brackets to secure NV14 to wall to prevent tip over.</p>	<p>Ensure all four (4) leveling feet are supporting the NV14. Do not 'hang' the NV14 from the wall brackets.</p>
	<p>Install wiring from Utility, Solar, and Critical Load Panel to appropriate breaker/fuse locations.</p>	<p>Follow all building and NEC codes when connecting wires and installing critical load breaker box.</p>
	<p>Install Three (3) Batteries</p>	<p>Ensure all batteries have proper ID settings and are in sleep mode prior to installing.</p> <p>Connect all three (3) Negative battery wires first. Connect all three (3) Positive battery wires second. Connect Battery communication cables.</p>
	<p>Apply Power and Verify System Settings</p>	<p>With all NV14 breakers in OFF position, turn on Grid Power When all breakers have correct voltage, turn on NV14 Disconnect Switch. Turn on a Battery. Then, turn on the inverter handle and green button. Once Normal LCD light illuminates, turn on Output Load breaker, then turn on AC and/or DC PV. Verify Inverter Settings.</p>
	<p>Install Cover Panels</p>	<p>Replace lower cover panel Replace Upper cover panel Install white screw caps</p>